

Type V30D(45)

Variable displacement axial piston pump



Product documentation

2026-04-30

Open circuit

Nominal pressure $p_{\text{nom max}}$: 420~450 bar

Peak pressure p_{max} : 450~500 bar

Geometric displacement V_{max} : 375~520 cm³/rev

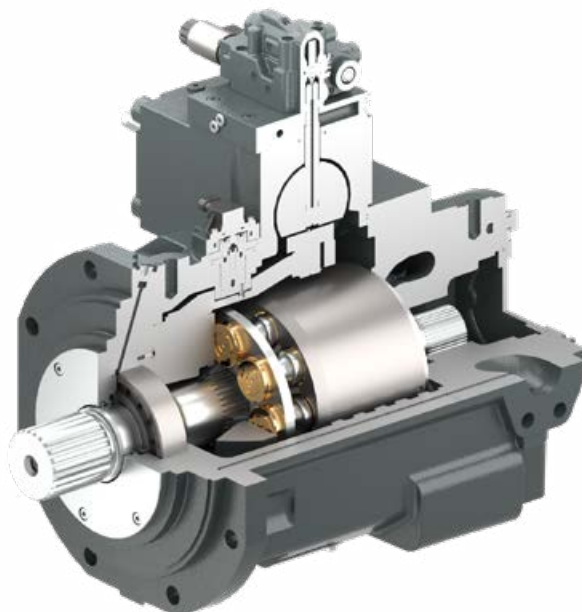

V30D-520

CATALOGUE

1	Overview: variable displacement axial piston pump types V30D(45)	03
2	Available versions, main data	04
2.1	Basic version	04
2.2	Controller switching symbols	07
2.3	Control module test curve	09
3	Parameters	11
3.1	General	11
3.2	Planning information for parameters	11
3.3	HLECC22112-I-AMP Controller	12
3.4	HLECC2414-PQP-PN Controller	15
3.5	Swing angle sensor (linear type)	18
3.6	Pressure sensor	19
4	Dimensions	20
4.1	V30D 375	20
4.2	V30D 500/520	22
5	Installation information	25
5.1	General	25
5.2	Oil circuit flushing	26
5.3	Connection between pump and system	27
5.4	Self suction of oil suction pipelines and pumps	27
5.5	Fuel tank	28
5.6	Oil leakage pipeline	29

1 Overview: variable displacement axial piston pump types V30D(45)

The axial piston variable displacement pumps of the type V30(45) of D offer extremely high function safety. Its remarkably low noise levels, the high pressure rating (peak = 420 bar / perm. = 350 bar), optimized power-to-weight-ratio as well as the wide controller range make it possible to employ it for most industrial and mobile applications. The variable displacement pumps work according to the swash plate principle: 9 pistons operate in a rotating cylinder cavities where they fulfill one suction and one pressure stroke per rotation.

Opening and closing of the cylinder cavities is via openings in the control disc. The axial movement of the pistons is provided by an adjustable swash plate. The setting angle (0 - max) can be steplessly varied in proportion to the desired displacement/flow. The setting range can be mechanically limited by setting screws (with V and VH controller only fixed limitation is possible).

All components used in the V30D are manufactured from high grade materials and machined with close tolerances. The wide range of modular controllers along with a thru-shaft (option for mounting auxiliary pumps or a second V30D) open up a wide range of application possibilities.

Therefore type V30D features a pump design, which ideally suits the special requirements of modern industrial, mobile hydraulic drive systems, marine, offshore, and other industries. Suitable for various pump controlled and valve controlled electro-hydraulic open systems. Conventional variable control mode and electronic pump closed-loop control mode are optional. High precision, high response, long lifespan, low noise, capable of achieving ideal minimum stable flow rate.

Features and benefits:

- High pressure and ultra-high pressure open hydraulic system.
- In addition to conventional pressure cutoff, load sensitivity, and constant power, it also has electro-hydraulic proportional and electro-hydraulic servo control modes.
- External or internal digital electro-hydraulic control amplifier.
- Integrated closed-loop control of flow rate, pressure, and power.
- Equipped with built-in variable speed adjustment function, which matches the variable speed motor to form a variable speed energy-saving system.
- Equipped with synchronous and volumetric efficiency compensation functions.
- Low noise, long lifespan, strong self-priming ability.
- Optional negative swing angle pressure relief mode.

Intended applications:

- Large forging equipment
- Super large excavator
- Extruder
- Industrial plants
- Marine cranes and winches
- Pile driving machine
- Power pack assembly
- Tunnel boring machine
- Ship engine



Type V30D-520

Variable displacement axial piston pump

2 Available versions, main data

2.1 Basic version

Circuit symbol:



Order coding example:

V30D 520 /45 R D7 G N 3 /PPQ4 01 -XXXX

Internal coding

Through axis drive

Table 8: Through axis drive

Controller

Table 7: Controller

Additional function

Table 6: Additional function

Seal

Table 5: Seal

Flange version (input side)

Table 4: Flange version (input side)

Shaft version

Table 3: Shaft version

Rotation direction

Table 2: Rotation Direction

Series No

Basic parameters

Table 1: Basic parameters

Product series

2.1 Basic version

Table 1: Nominal size

Code	Geometric displacement (cm ³ /rev.)	Nominal pressure p _{nom} (bar)	Peak pressure p _{max} (bar)
375	375	420	450
500	500	450	500
520	520	420	450

Table 2: Rotating directions

Code	Description	Product model		
		375	500	520
L	Anti-clockwise (From the direction of the drive shaft)	○	●	●
R	Clockwise (From the direction of the drive shaft)	●	●	●
B*	Both directions	○	○	○

 Note: “*” If you need to make a selection, please contact Hengli Hydraulic Co., Ltd. to confirm more detailed usage requirements.

Table 3: Shaft versions

Code	Description	Designation/Standard	Max. drive torque (N · m)	Product model		
				375	500	520
D6	Spline shaft D	DIN 5480 W70×3×22×9g	5250	●		
D7	Spline shaft D	DIN 5480 W80×3×25×9g	5566		●	●
K5	Key shaft K	DIN 6885 φ80 AS 22×14×125	5200		●	●
K6	Key shaft K	DIN 6885 φ70 AS 20×12×100	3557	●		

Table 4: Flange versions (input side)

Code	Description	Designation	Product model		
			375	500	520
G	Flange	ISO 3019-2 224-4			
		ISO 3019-2 315-8		●	●

Table 5: Seals

Code	Description
N	NBR (nitrile rubber)
V	FKM (fluororubber)

2.1 Basic version

Table 6: Additional function

Code	Description
0	None
1	Mechanical display with inclined plate swing angle
2	With a tilt angle sensor 2V-10V
3	With a tilt angle sensor 2V-10V and a pressure sensor of 0V-10V
4 ¹	With a tilt angle sensor 4mA-20mA
5 ¹	With a tilt angle sensor 4mA-20mA and a pressure sensor of 4mA-20mA
6	Mechanical display with inclined plate swing angle and With a tilt angle sensor 2V-10V
7 ¹	Mechanical display with inclined plate swing angle and With a tilt angle sensor 4mA-20mA
8	Equipped with a mechanical display for inclined plate swing angle, inclined plate swing angle sensor 2V-10V, and pressure sensor 0V-10V
9 ¹	Equipped with a mechanical display for inclined plate swing angle, inclined plate swing angle sensor 4mA-20mA, and pressure sensor 4mA-20mA



 Note: “*” Mean is priority selection of model.

Table 7: Controller

Code	Control type	Product model		
		375	500	520
VNL	Constant Power + Pressure Cutoff + Electrically Proportional Displacement	●	●	●
VPL	Constant Power + Remote Pressure + Electrically Proportional Displacement	●	●	●
NP	Remote Pressure + Pressure Cut-off	●	●	●
LNP	Constant Power + Remote Pressure + Pressure Cut-off	●	●	●
LSN	Pressure Cut-off + Load Sensing	●	●	●
LLSN	Constant power+pressure cutoff+load sensitivity	●	●	●
PD4/5	Parallel pressure control	○	○	○
EC2 ^{*1*2}	Flow+Controller HLEC-22112-I-AMP	●	●	●
EC3 ^{*1*2}	Flow+Controller HLEC-2414-PQP-PN	●	●	●
PPQ1 ^{*1*2}	Power/Pressure/Flow+Controller HLEC2414-PQP-PN	●	●	●
PPQ4 ^{*1*2}	Power/Pressure/Flow+Controller HLEC2414-PQP-PN	●	●	●

 Note: “*1” Control oil supply, control pressure range 150-250bar, maximum system pressure ≤ 450bar, starting pressure>50bar.

“*2” When selecting control modules EC2, EC3, PPQ4, it is generally necessary to use it together with a controller.

Table 8: Through axis drive

Code	Description	Product model		
		375	500	520
None	No axial drive, standard back cover	●	●	●
	Mounting flange			
	Internal spline			
01	ISO 3019-1 165-4		●	●
02	ISO 3019-2 315-8		●	●

 Note: 1. Pay attention to the maximum allowable driving torque, otherwise it may cause damage to the flange or shaft!
2. When multiple pumps are combined (pump quantity ≥ 3), it is recommended to equip additional supports by oneself.
3. If you need other specifications of axial drive, please contact us.

● = Available ○ = Under development

2.2 Controller switching symbols

VNL

Constant Power + Pressure Cutoff + Electrically Proportional Displacement

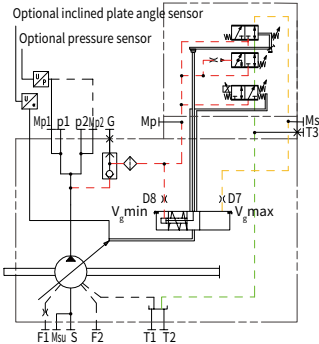

VPL

Constant Power + Remote Pressure + Electrically Proportional Displacement

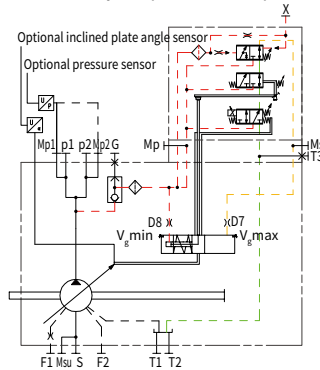

NP

Remote Pressure + Pressure Cut-off

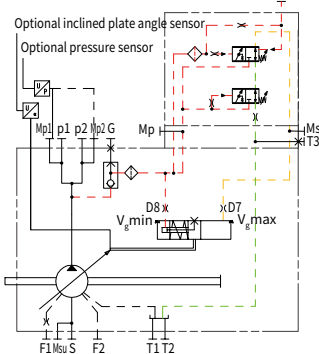

LNP

Constant Power + Remote Pressure + Pressure Cut-off

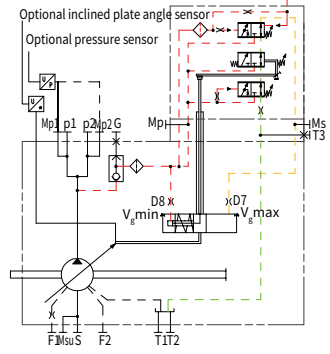

LSN

Pressure Cut-off + Load Sensing

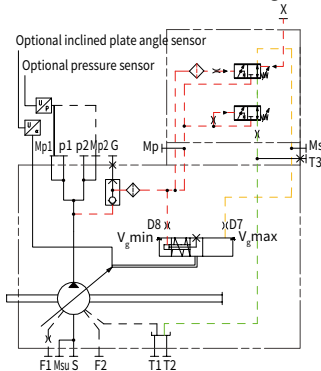

LLSN

Constant power+pressure cutoff+load sensitivity

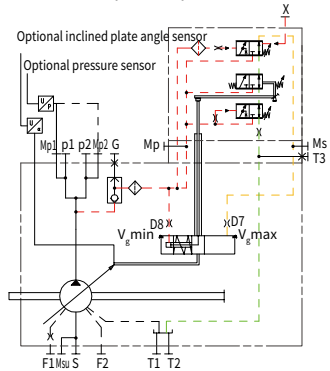

2.3 Control module test curve (Taking V30D520 as an example)

Displacement hysteresis curves

■ **Test conditions:**

At a speed of 1500rpm, Set the outlet pressure of the pump to 315bar and the pilot pressure to 190bar. And test the relationship curve between different input voltages and the pump's tilt angle.

■ **Test result:**

The input signal is 5% → 95% → 5%, take the maximum hysteresis value in the hysteresis curve as the test result.

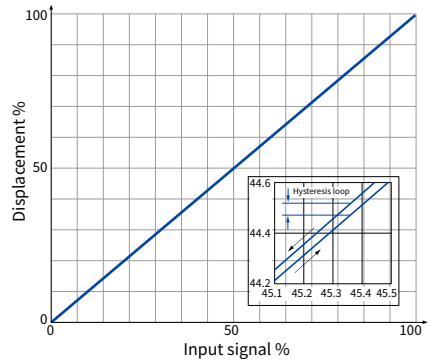

0~100% Step response of swing angle

■ **Test conditions:**

At a speed of 1500rpm, Set the outlet pressure of the pump to 315bar and the pilot pressure to 190bar at maximum displacement (520cc/rev).

■ **Test result:**

The input signal is 0 → 100%, and the feedback value of the pump swash plate swing angle is used as the rising step time.

The input signal is 100% → 0, and the feedback value of the pump swash plate swing angle is used as the descent step time.

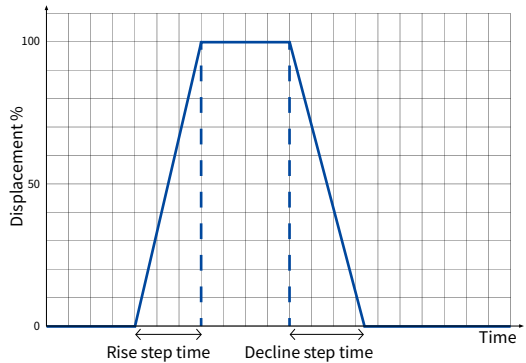

2.3 Control module test curve (Taking V30D520 as an example)

Structural parameter

Type		V30D 375	V30D 520
Control diameter	mm	62.5	70
Control stroke	mm	30.5	34.5
Control volume	cm ³	93.5	132.7
Actuating time	s	0.12	0.15
Control pressure	MPa	12.5min	19min
Control flow	L/min	46.8	53.1

Performance parameter

	Hysteresis loop	Linearity	0-100% step response time	Minimum stable flow rate
EC2	3 %	2 %	≤ 300 ms	5 L/min
EC3	0.2 %	0.2 %	≤ 150 ms	2.5 L/min
PPQ1	3 %	2 %	≤ 300 ms	5 L/min
PPQ4	0.05 %	0.2 %	≤ 150 ms	2.5 L/min

Pressure-Flow-Power Curve

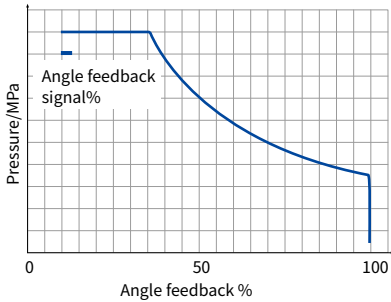

Pressure flow/power curve

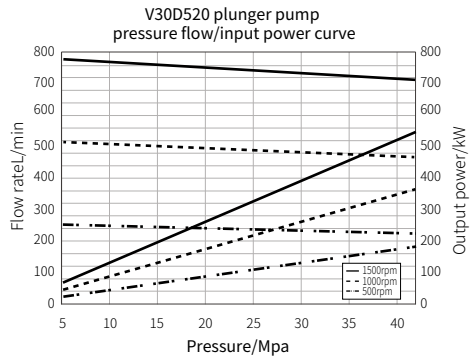

3 Parameters

3.1 General

Technical Parameter

Product model		375	500	520
Displacement $V_{g,max}$	cm ³ /rev	375	500	520
Nominal pressure p_{nom}	bar	420	450	420
Peak pressure p_{max}	bar	450	500	450
Weight (without control module)	kg	240	335	330
Oil suction pressure $p_{abs} = 1$ bar, Displacement V_g The maximum achievable speed at maximum $n_{0,max}$	rpm	1650	1500	1500
Increased oil suction pressure, Displacement V_g The maximum achievable speed when the displacement is less than the maximum $n_{0,max}$	rpm	1800	1650	1500
Maximum flow (1500 rpm) Q	L/min	562.5	750	780
Case pressure p_L (nominal pressure / peak pressure)	bar	2/3	3/5	3/5



Note:

The minimum operating pressure in the pump line depends on the speed and the washplate angle; the pressure must not fall below 15 bar under any circumstances.

3.2 Planning information for parameters

Determination of nominal sizes

Delivery flow	$Q = \frac{V_g \cdot n \cdot \eta_v}{1000} \text{ (lpm)}$	V_g	= Geom. output volume (cm ³ /rev)
		Δp	= Differential pressure (bar)
Drive torque	$M = \frac{V_g \cdot \Delta p}{20 \cdot \pi \cdot \eta_{mh}} \text{ (Nm)}$	n	= Rotation speed (rpm)
		η_v	= Volumetric efficiency
Drive power	$P = \frac{2\pi \cdot M \cdot n}{60000} = \frac{Q \cdot \Delta p}{600 \cdot \eta_t} \text{ (kw)}$	η_{mh}	= Mechanical-hydraulic efficiency
		η_t	= Overall efficiency ($\eta_t = \eta_v \cdot \eta_{mh}$)

3.3 HLEC-22112-I-AMP Controller

Suitable for closed-loop control of one directional valve, two pressure valves, or two throttle valves, or for closed-loop control of the angle of the inclined disc of an axial piston variable displacement pump.

Electrical parameter table

Input voltage	12V~30V DC
Operating Temperature	-20°C ~+85°C
Storage temperature	-20°C ~+105°C
Relative humidity	45%~90%
Protection level	IP20
Electrical protection	Power input reverse connection protection, power output overcurrent and short circuit protection, port electromagnetic protection Signal port input/output overvoltage/overcurrent protection, port electromagnetic protection
Communication method	USB TYPE-B
Overall dimensions	114mm*99mm*22.6mm
Analog input	1-channel: 0~5V or 4~20mA; 1-channel: 0~10V or 4~20mA
Digital input	2-channels, high efficiency (>10V)
Digital Output	2-channel, high: 24V; low: 0V
Analog output	1-channel, 0~10V
Electromagnetic valve output	2-channels, output range 0~2.6A
Debugging serial port baud rate	9600~115200
Connector	MSTBT2.5/4-ST KMGY, MSTBO2.5 4-G1L KMGY, MSTBO2.5 4-G1R KMGY
Product testing types	Functional testing, environmental testing, EMC

3.3 HLEC-22112-I-AMP Controller

Pin function definition

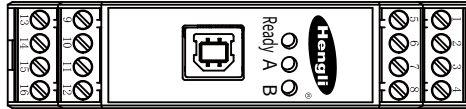

Pin	Description	Main functions
PIN 1/2	Current output A channel	PWM control current B output 0~2.6A
PIN 3/4	Current output B channel	PWM control current A output 0~2.6A
PIN 5	Switching Output	High: 24V; Low: 0V
PIN 6	Switch quantity A channel input	Highly effective (>10V)
PIN 7	Power input +	Power supply, positive pole of power supply
PIN 8	Power input -	Power supply, negative pole of power supply
PIN 9/10	Analog input A channel	Input range: 0~10V or 4~20mA
PIN 11	PE	Earth Ground Line
PIN 12	Analog output	Output range 0~10V
PIN 13/14	Analog input B channel	Input range: 0~5V or 4~20mA
PIN 15	Switch quantity B channel input	Highly effective (>10V)
PIN 16	NC	

3.3 HLEC-22112-I-AMP Controller

Controller installation dimensions

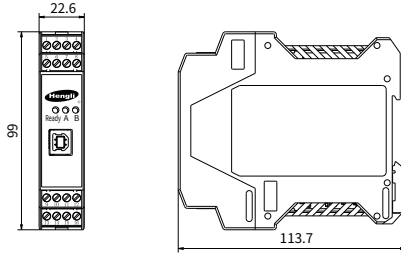

Wiring example

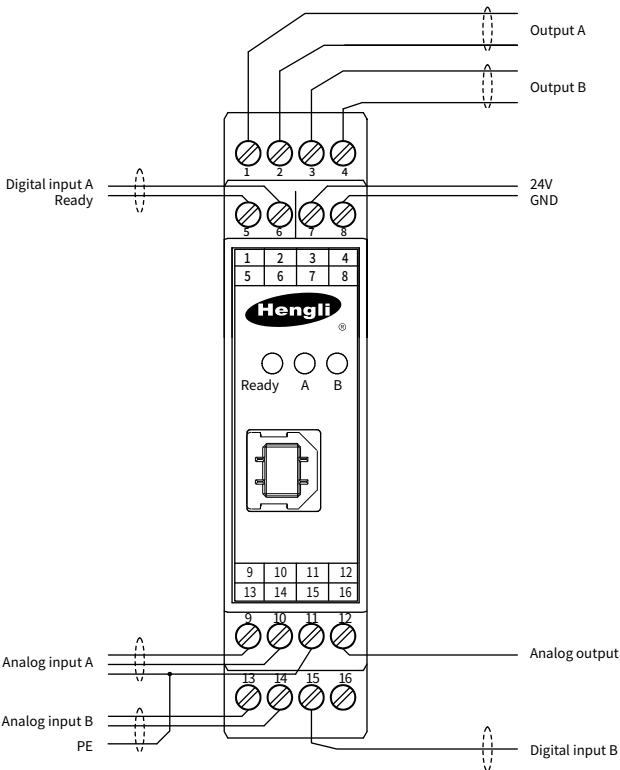

3.4 HLEC2414-PQP-PN Controller

An electronic pump control module that integrates power and control interfaces, suitable for flow, pressure, and power control of electronic pumps.

Electrical parameter table

Input voltage	12V~30V DC
Operating temperature	-20°C ~+85°C
Storage temperature	-20°C ~+105°C
Relative humidity	45%~90%
Protection level	IP20
Electrical protection	Power input reverse connection protection, power output overcurrent and short circuit protection, port electromagnetic protection Signal port input/output overvoltage/overcurrent protection, port electromagnetic protection
Communication method	USB TYPE-B
Overall dimensions	114mm*99mm*22.6mm
Analog input	1-channel: 0~5V or 4~20mA; 1-channel: 0~10V or 4~20mA
Digital input	2-channels, high efficiency (>10V)
Digital Output	2-channel, high: 24V; low: 0V
Analog output	1-channel, 0~10V
Electromagnetic valve output	2-channels, output range 0~2.6A
Debugging serial port baud rate	9600~115200
Connector	MSTBT2.5/4-ST KMGY, MSTBO2.5 4-G1L KMGY, MSTBO2.5 4-G1R KMGY
Product testing types	Functional testing, environmental testing, EMC

Control topology block diagram

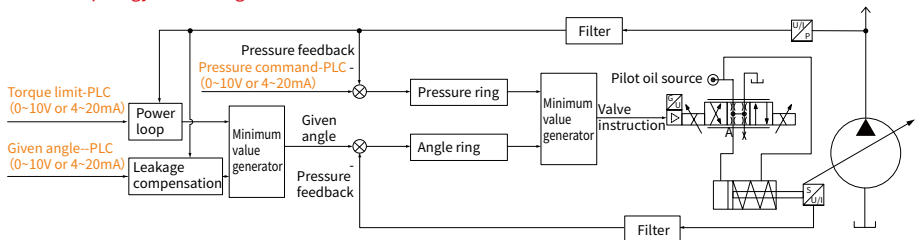

3.4 HLEC2414-PQP-PN Controller

Pin function definition

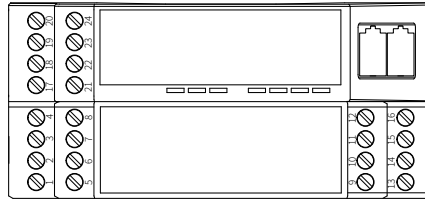

Pin	Description	Main functions
PIN 1	Digital output	+24V is output ON: The module is enabled there are no discernible errors. OFF: ENABLE is not available or an error has been detected.
PIN 2	Digital output	High-side digital output +24V (reserved)
PIN 3	DC +24V	Power supply, positive pole of the power supply
PIN 4	DC -24V (GND)	Power supply, negative pole of the power supply
PIN 5	Analog input signal 2	Analog input 0-10V
PIN 6	Analog input angle 1	Feedback value: swivel angle, with a signal range of 0... 10 V or 4... 20 mA, scalable.
PIN 7	Analog input signal 3	Analog input 0-10V
PIN 8	Analog input signal 1	This application is usually enabled.
PIN 9	Analog input ratio 1	Analog input 0-5V
PIN 10	Analog input ratio 2	Analog input 0-4.5V
PIN 11	Analog input GND	0 V (GND) reference potential for analog input signal
PIN 12	Analog output signal 0 V (GND)	0 V (GND) reference potential for analog output signal
PIN 13	Analog input pressure 1	Feedback value 1: pressure, with a signal range of 0... 10 V or 4... 20 mA, scalable.
PIN 14	Analog input pressure 2	Feedback value 2: pressure, with a signal range of 0... 10 V or 4... 20 mA, scalable.
PIN 15, PIN 12	Analog output control 1	Control output : 0... 10 V or 4... 20 mA, configurable
PIN 16, PIN 12	Analog output control 2	Control output : 0... 10 V or 4... 20 mA, configurable
PIN 17, PIN 19	Solenoid A output	Solenoid A output : MAX 2A or MA X 3.2A, configurable
PIN 18, PIN 20	Solenoid B output	Solenoid B output : MAX 2A or MA X 3.2A, configurable
PIN 21	Digital output	High-side digital output +24V (reserved)
PIN 22	DC+24 V	Solenoid power supply, positive pole of the power supply
PIN 24	DC -24V (GND)	Solenoid power supply, negative pole of the power supply
LINKACT 1/ LINKACT 2	Network ports 1 and 2	ProfiNet RJ45 network signal

3.4 HLEC2414-PQP-PN Controller

Controller installation dimensions

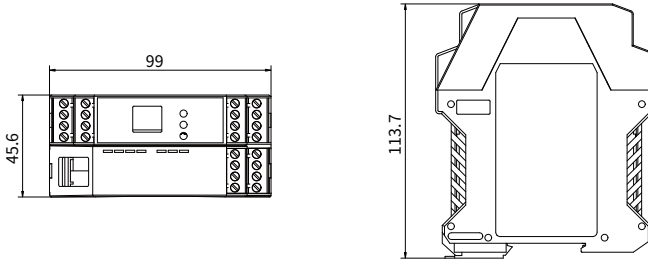

Wiring example

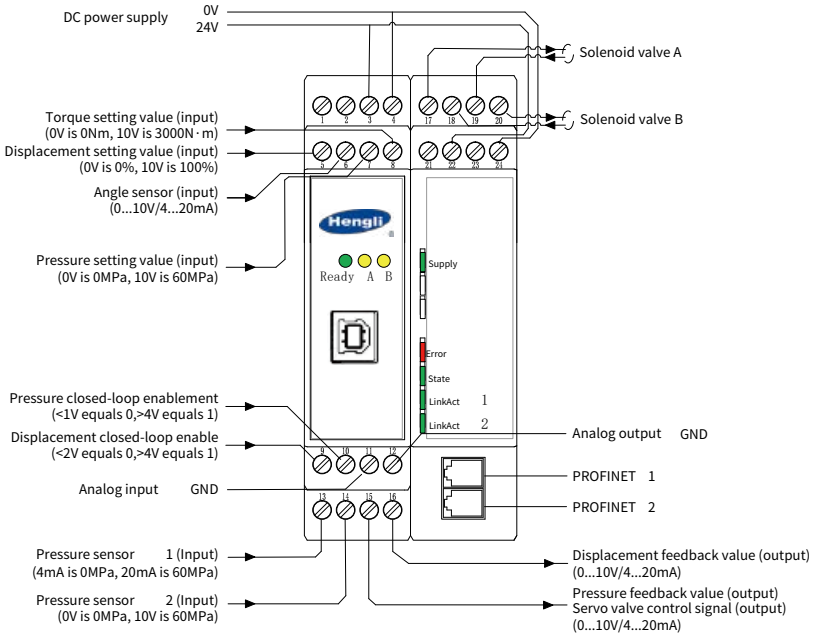

3.5 Swing angle sensor (linear type)

Technical Parameter

Supply voltage	18~ 30 VDC
No load current consumption	< 60 mA
Output signal	2 ~ 10 V / 4 ~ 20 mA
Upper limit frequency	500 Hz
Measuring range	±4mm
Linear deviation	±1%
Operation temperature	-20 °C ~ +75 °C



External dimensions

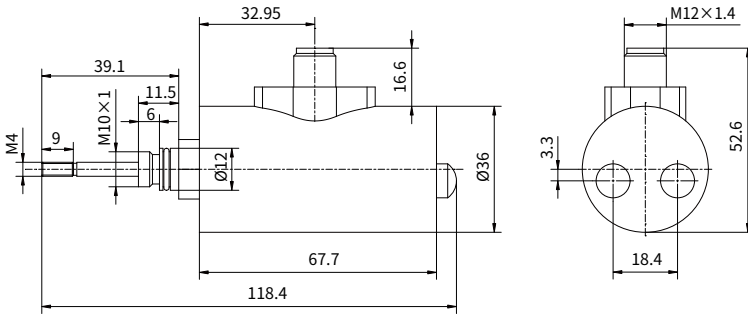

Pin definition

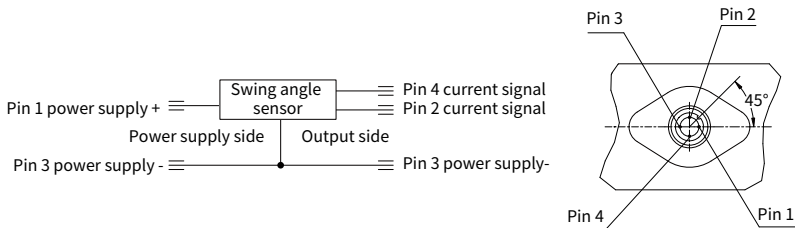

3.6 Pressure sensor

Technical Parameter

Pressure range	0-60 MPa
Supply Voltage	8-36 V
Output signal	0 ~ 10 V / 4 ~ 20 mA
Long term stability	±0.2%FS
Overload pressure	2.5 times
Response time	≤1ms
Zero temperature drift	±0.1%FS/10°C
Working temperature	-40-105°C
Protection level	IP67
Working medium	Compatible with 17-4 material



External dimensions

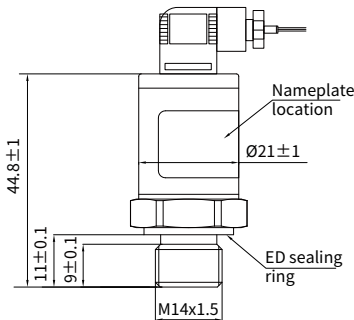

Pin definition

Voltage-type Pressure Transducer

Pin 1	V+
Pin 2	N/C
Pin 3	V-
Pin 4	V _{out}

Current-type Pressure Transducer

Pin 1	V+
Pin 2	Out
Pin 3	N/C
Pin 4	N/C

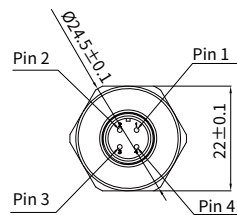

4 Dimensions

All dimensions in mm, subject to change!

4.1 V30D375 series

4.1.1 V30D375 , clockwise rotation

VPL — Volume of flow-Pressure(telecontrol)-Torque

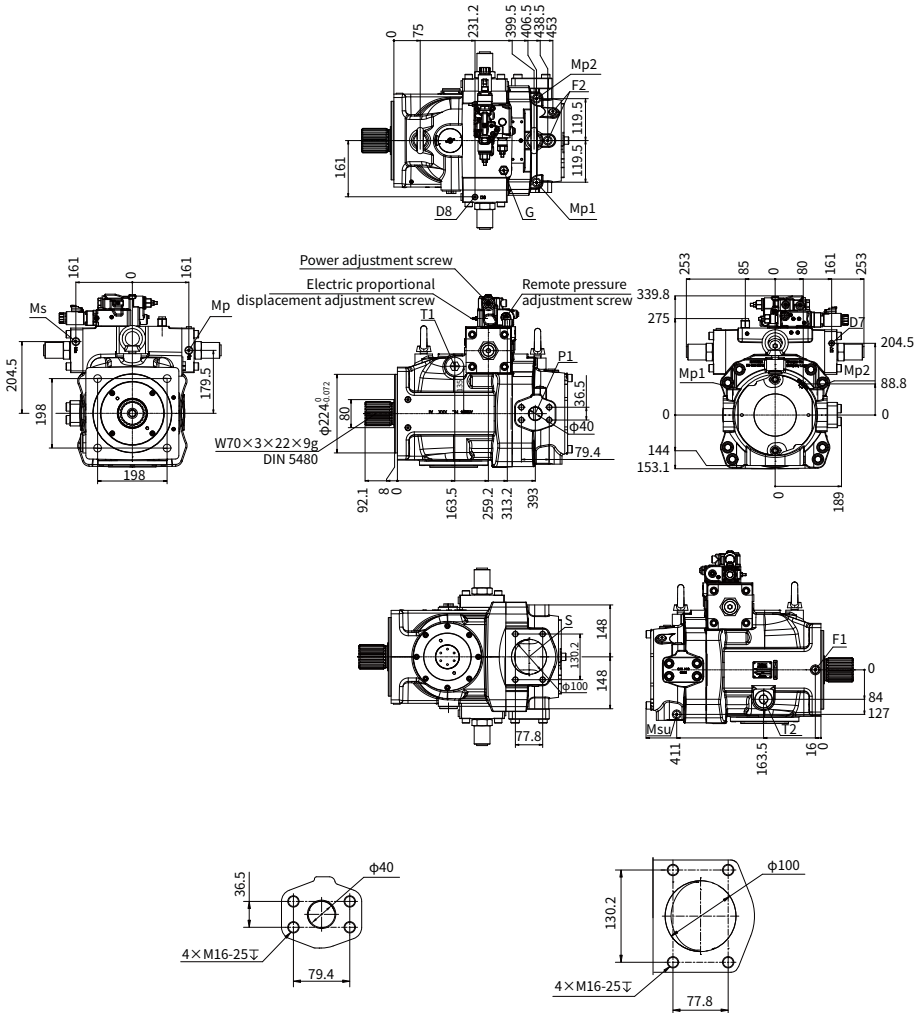

Pressure port P1, P2

Suction port S

4.1.1 V30D375 , clockwise rotation

Axis structure form

Spline shaft Model D6

(DIN 5480 W70×3×22×9g)

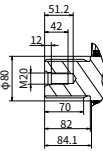

Spline shaft Model K6

(DIN 6885 φ70 AS 20×12×100)

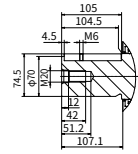

Port details

Port details	Designation	Standard	Size	Notes
S	Input port	SAE J518 code 61 DIN 13	4 in M16; depth 25	Flange cover plate protection
P1	Output port	SAE J518 code 62 DIN 13	1 1/2 in M16; depth 25	Flange cover plate protection
P2	Output port	SAE J518 code 62 DIN 13	1 1/2 in M16; depth 25	Flange cover plate protection
G	Pilot oil port	ISO 1179	G1/4 depth 12.5	According to the control mode configuration, the G-port internal control can be selected when the pump working pressure is ≤ 315 bar; The electronic pump should prioritize the external control method, and the G port should be sealed with a screw plug.
Mp1, Mp2	P1 and P2 outlet pressure gauges	DIN 3852- X series	M14×1.5; depth 12	Screw plug protection during delivery
X1	Remote pressure oil port	DIN 3852- X series	M14×1.5; depth 12	Screw plug protection during delivery
Mp	High pressure chamber oil measuring port	DIN 3852- X series	M14×1.5; depth 12	Screw plug protection during delivery
Ms	Control pressure tap	DIN 3852- X series	M14×1.5; depth 12	Screw plug protection during delivery
Msu	Oil suction pressure tap	DIN 3852- X series	M14×1.5; depth 12	Screw plug protection during delivery
T1	Drain port	DIN 3852- X series	M42×2; depth 20	When in use, it is necessary to connect the upper oil drain port (protected by a plastic screw plug)
T2	Drain port	DIN 3852- X series	M42×2; depth 20	When in use, it is necessary to connect the upper oil drain port (protected by a steel screw plug)
F1	Bearing flushing hole	ISO 1179	G1/4 depth 12.5	Refer to the instructions for flushing the oil circuit (delivered with screw plug protection)
F2	Bearing flushing hole	DIN 3852- X series	M14×1.5; depth 12	Refer to the instructions for flushing the oil circuit (delivered with screw plug protection)
D7	Throttle setting hole	DIN13	M8; depth 11	Select according to actual working conditions and requirements
D8	Throttle setting hole	DIN13	M8; depth 11	Select according to actual working conditions and requirements

4.2 V30D500/520 series

4.2.1 V30D500/520 , clockwise rotation

PPQ4 — Power/Pressure/Flow+Controller HLEC2414-PQP-PN

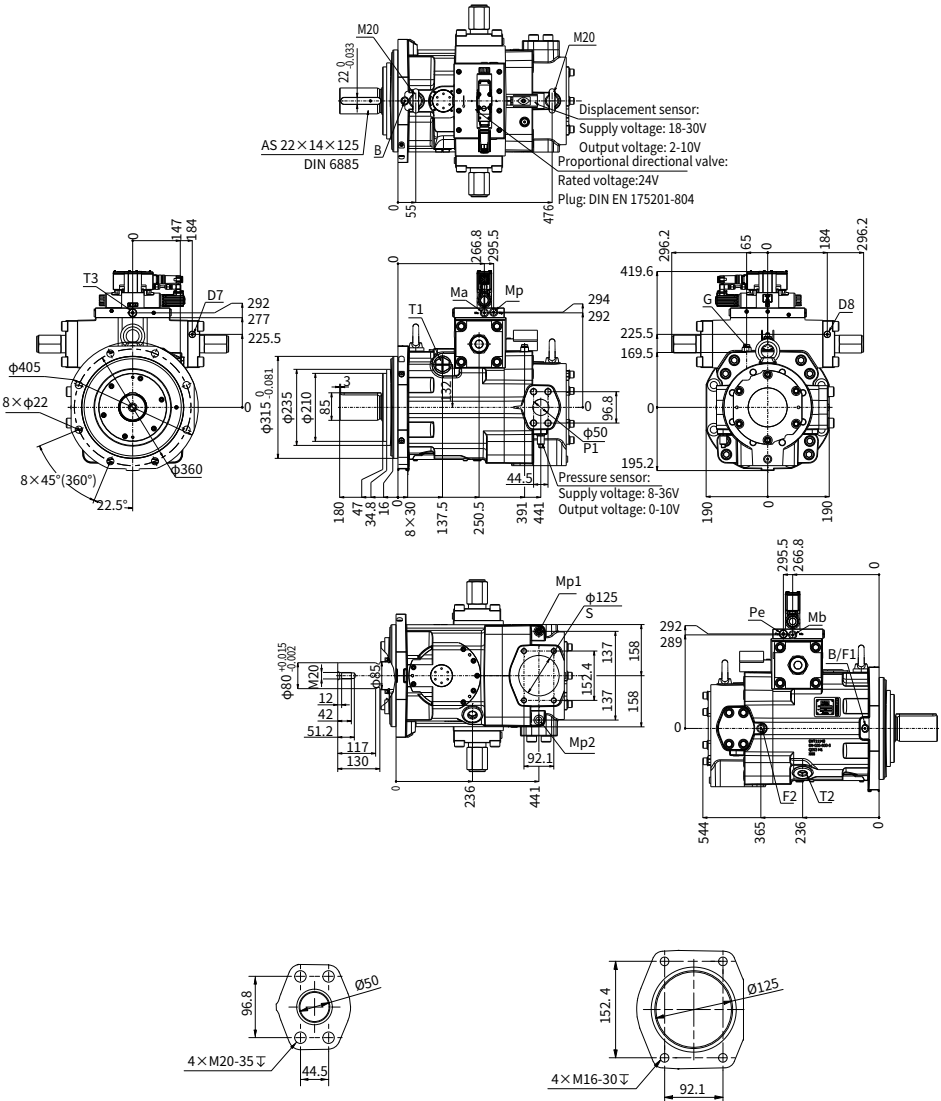

Pressure port P1, P2

Suction port S

4.2.1 V30D500/520 , clockwise rotation

Axis structure form

Spline shaft Model D7

(DIN 5480 W70×3×22×9g)

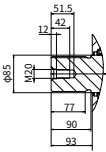

Key shaft Model K5

(DIN 6885 φ80 AS 22×14×125)

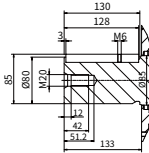

Port details

Port details	Designation	Standard	Size	Notes
S	Input port	SAE J518 code 61 DIN 13	5 in M16; depth 30	Flange cover plate protection
P1	Output port	SAE J518 code 62 DIN 13	2 in M20; depth 35	Flange cover plate protection
P2	Output port	SAE J518 code 62 DIN 13	2 in M20; depth 35	Flange cover plate protection
G	Pilot oil port	DIN 3852- X series	M14×1.5; depth 12	According to the control mode configuration, the G-port internal control can be selected when the pump working pressure is ≤ 315 bar; The electronic pump should prioritize the external control method, and the G port should be sealed with a screw plug.
Mp1, Mp2	P1 and P2 outlet pressure gauges	DIN 3852- X series	M14×1.5; depth 12	Screw plug protection during delivery
Ma, Mb, Mp	Control oil pressure tap	DIN 3852- X series	M14×1.5; depth 12	Screw plug protection during delivery
Pe	External pilot port	DIN 3852- X series	M18×1.5; depth 12	Screw plug protection during delivery
Msu	Oil suction pressure tap	DIN 3852- X series	M14x1.5; depth 12	Screw plug protection during delivery
T1	Drain port	DIN 3852- X series	M48×2; depth 22	When in use, it is necessary to connect the upper oil drain port (protected by a plastic screw plug)
T2	Drain port	DIN 3852- X series	M48×2; depth 22	When in use, it is necessary to connect the upper oil drain port (protected by a steel screw plug)
T3	Drain port	DIN 3852- X series	M18×1.5; depth 12	When the pump is installed horizontally or the control mechanism is facing upwards, T3 exhaust ¹ (steel screw plug protection) can be used
F1, F2	Bearing flushing hole	DIN 3852- X series	M14×1.5; depth 12	Refer to the instructions for flushing the oil circuit (delivered with screw plug protection)
B	Exhaust port	DIN 3852- X series	M14×1.5; depth 12	When installed horizontally or vertically with the drive shaft facing upwards, it can be used for exhaust (delivered with screw plug protection)
D7	Throttle setting hole	DIN13	M8; depth 11	Select according to actual working conditions and requirements
D8	Throttle setting hole	DIN13	M8; depth 11	Select according to actual working conditions and requirements

Note: “**1” When using electronic control mode, using T3 oil drain can improve dynamic performance.

4.2 Control module (V30D500/520)

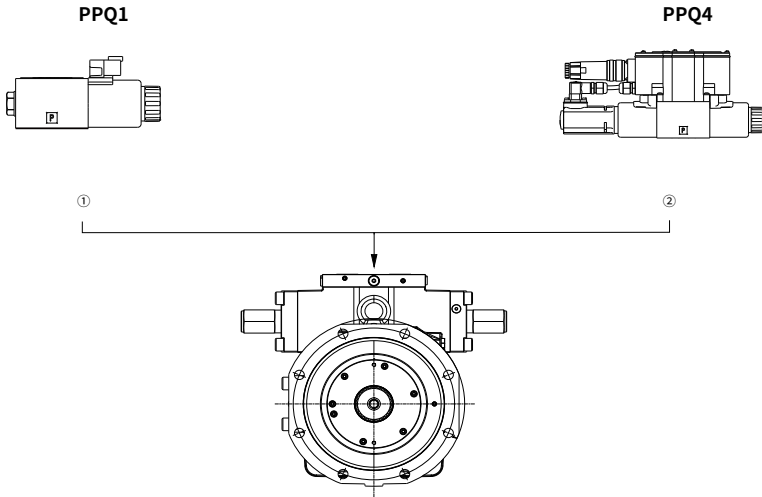

- ① . PPQ1: Direct acting proportional directional valve: rated voltage: 24V plug: DIN EN 175301-803
- ② . PPQ4: Direct acting proportional directional valve: rated voltage: DIN EN 175201-804

The symbols for the PpQ control module are shown in the table below

Controller	Controller switching symbols	Initial position (power-off state)
PPQ1		$V_g \text{ min}$
PPQ4		$V_g \text{ min}$

5 Installation information

5.1 General

5.1.1 Precautions for pump installation and use

- 1.The following interfaces must be connected when installing the pump into the hydraulic system:
 - Fix the pump casing and base flange through mechanical connection
 - The shaft is connected to the drive motor through an elastic coupling
 - The pump suction port is connected to the fuel tank through a shock absorber throat
 - The pressure oil port is connected to the subsequent system through a hose
 - Remote control is connected to the pilot valve through a hose
 - If the variable mechanism controls the oil using an external control method, it needs to be connected to the pump through a hose
 - If the pump drive shaft is installed upright and facing upwards, the internal air should be evacuated through the exhaust port on the pump body
- 2.Installation and debugging can only be carried out by professionals. Please ensure that all connections are tightened according to standards, and do not connect any oil ports of the pump to the common return line of the oil tank. If unavoidable, please ensure that the allowable pump housing pressure range is not exceeded.
- 3.Before officially putting into operation, the pump casing must be filled with oil according to relevant requirements, otherwise the dry friction of the internal friction pair of the pump will cause damage to itself within a few hours of operation.
- 4.Before initial operation, operate the idle handwheel or jog the spindle to confirm that hydraulic oil is discharged from the pressure port.
- 5.When operating under pressure, it is recommended to gradually increase the pressure in stages.
6. The optimal viscosity range for piston pump operation is between 16cSt and 36cSt, which is more conducive to pump service life and reliability. The continuous operation viscosity range is 10–400cSt.
7. Always ensure the use of the pump leakage ports T1, T2, or T3 (used when controlling external oil leakage) located at the top of the pump body.

5.1.2 Precautions for Controller Installation and Use

- 1.Before debugging, please check that all seals and plugs for plug-in connections are installed correctly to ensure that no liquid or solid foreign objects enter the product.
- 2.This module is designed to be installed in a shielded EMC enclosure (control cabinet). The distance from overhead power lines, wireless power sources, radar, mobile phones and other equipment should be at least 1m. Avoid installing the controller near strong electromagnetic interference sources. The installation location should not be chosen near power electronic equipment (such as frequency converters), while avoiding prolonged exposure of the equipment to ultraviolet radiation.
- 3.Ensure that the installation location is easy to maintain, allowing unobstructed access to the connecting wires and parts.
- 4.The controller HLEC2414-PQP-PN and power supply device should be installed as close as possible to ensure that the connecting wires are as short as possible.
- 5.For signal cables, please only use low capacitance cables with copper braided shielding layers and connect them extensively to one side of the cable shielding layer using grounding strips. Do not pass signal cables through strong magnetic fields, try to install signal cables continuously as much as possible. If intermediate terminals are required, please use wiring terminals with shielded busbars. Do not lay signal cables near power lines.
- 6.Before carrying out any installation work or unplugging connection wires from the product, please disconnect the power supply of the device. Please ensure that the product is only used within the IP20 protection level to avoid short circuits and malfunctions.
- 7.Maintenance: When the controller HLEC2414-PQP-PN is working, please follow strict cleanliness requirements. To prevent moisture and dirt from entering the casing, only use a dry and dust-free cloth for cleaning, and do not use solvents or corrosive cleaning agents. At least once a year, check whether all plug-in connections and clamping connections of the controller are correctly installed or damaged. Check all cables for breakage or compression.

5.2 Oil circuit flushing

1. In situations where the oil temperature is too high (≥ 75 °C in any part of the pump body), such as high pressure overload, continuous working pressure ≥ 300 bar, and harsh working conditions, it is recommended to add a front and rear bearing flushing circuit to extend the service life of the front and rear bearings.
2. When installing the transmission shaft vertically upwards, external flushing must be added.
3. When F1 and F2 ports are used for flushing, suitable throttling plugs should be selected to adjust the flushing flow rate (reference flushing flow rate 11L/min) to ensure that the shell pressure is within the allowable range (≤ 3 bar, it is recommended to reserve no less than 30% redundancy for new system debugging). The flushing oil flows through the front and rear bearings and is discharged through the pump's drain port. When in use, the flow plug must be tightened and thread sealant should be applied if necessary.
4. The installation threaded hole specification for the throttle plug is $M8 \times 1.25$.
5. Standard/default supply does not include flushing functionality. Please consult Hengli Hydraulics before ordering to determine if flushing functionality is required for your application.

**Variable displacement pump
with flushing function**

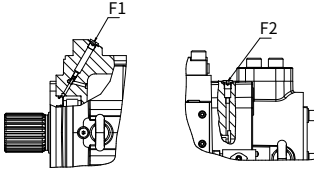

**Variable displacement pump
without flushing function**

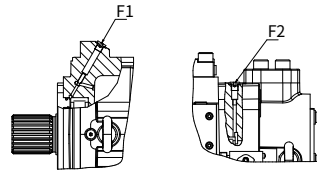

**Quantitative pump
with flushing function**

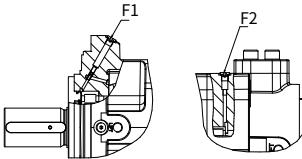

**Quantitative pump
without flushing function**

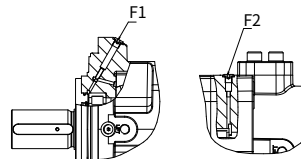

5.3 Connection between pump and system

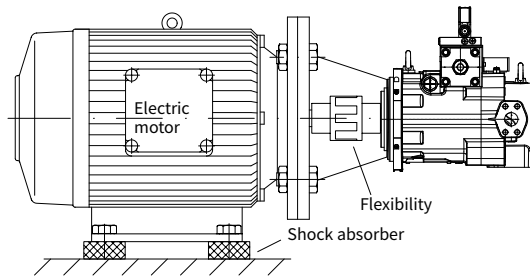

An elastic coupling should be installed between the drive shaft and the pump shaft to prevent the vibration and impact of the prime mover (such as a diesel engine) from being transmitted to the pump shaft. If the pump is driven by a universal shaft or gearbox, an elastic coupling should also be installed in front of the pump. Use a bell shaped cover that meets the accuracy requirements.

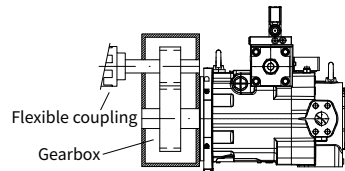

5.4 Self suction of oil suction pipelines and pumps

The inner diameter of the oil suction pipeline must be greater than the inner diameter of the pump oil suction flange. The inner diameter of the oil suction pipeline should increase by 1 centimeter per meter. The maximum cross-section of the entire oil suction pipeline should be at the end connected to the fuel tank. The suction pipe end of the fuel tank should be cut at a 45 degree angle or cut into an open funnel shape. If a fuel tank is connected to multiple suction pipes, the minimum distance between the two suction pipes is 5 times the outer diameter of the suction pipes. The pipe end should be at least 8 times the diameter of the suction pipe below the fuel tank level and 2 times the diameter of the suction pipe above the bottom of the fuel tank. The variable diameter channel between two different diameters should be made into a cone shape. When bending a pipe, it should be bent with the maximum possible radius. The diameter of the oil suction ball valve cannot be smaller than the diameter of the oil suction pipe. If multiple oil suction pipes are connected to a main pipe, the cross-section of the main pipe must be at least the sum of the cross-sections of the branch oil suction pipes. The branch and main oil suction pipeline should be connected using conical fittings, and the conical fittings should not interfere with the cross-section inside the main oil suction pipeline. The oil suction pipeline near the pump should be connected with flexible hoses or pipe fittings. It should be noted that when installing pipeline connectors, the axis of the pump and compensator should be on the same plane. This ensures that the pressure caused by the torsional vibration of the pump on the connecting components is lateral pressure rather than longitudinal pressure. Otherwise, the longitudinal pressure acting on the connecting components will cause cavitation and noise.

5.5 Fuel tank

The fuel tank should contain at least two oil chambers, separated by baffles to ensure that the return and drain oil are separated from the suction port. In this way, pollutants can precipitate and cause bubbles to rise to the surface. Filters and coolers should be placed on the return oil pipeline or auxiliary circuit. The size of the air filter used should be large enough, that is, the airflow at a pressure difference of 0.1 bar should be the same as the airflow generated at the maximum oil flow rate. The liquid level in the fuel tank should always be higher than the suction port of the self-priming pump. Basically, the oil suction pipeline should be directly connected from the fuel tank and pump. However, it should be avoided to form one or more circular arches, otherwise air will gather at the top, resulting in noise and cavitation, and it will take some time for the air to be completely expelled.

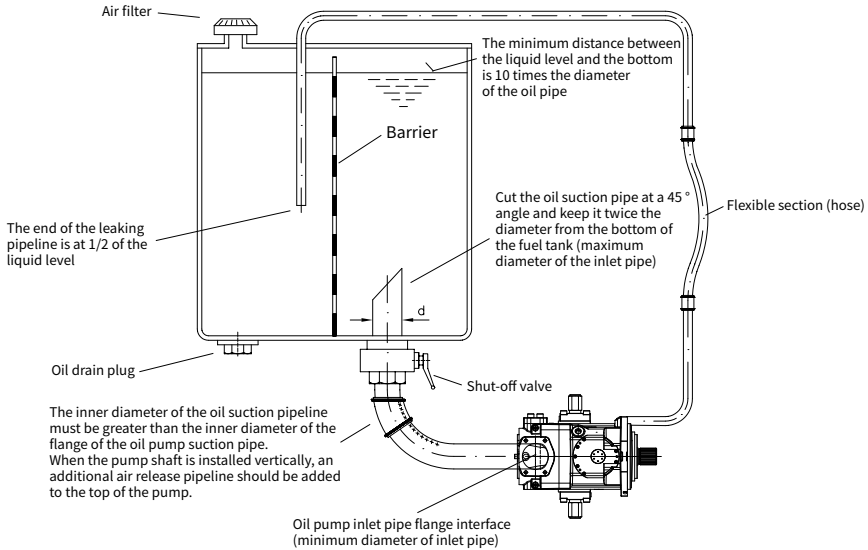

5.6 Oil leakage pipeline

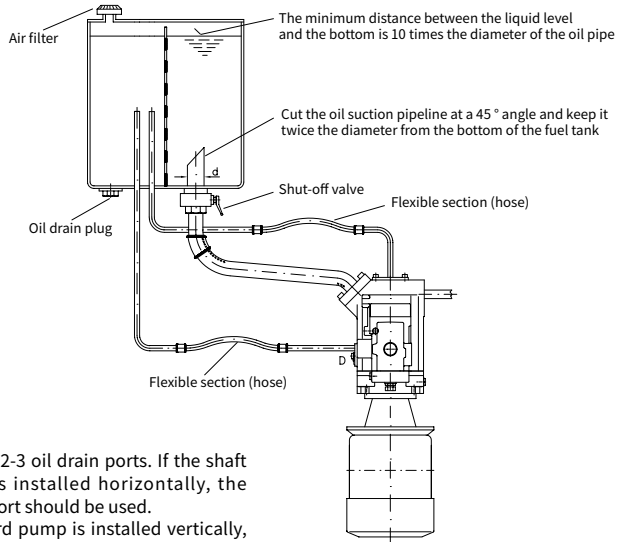

The pump housing has 2-3 oil drain ports. If the shaft of a standard pump is installed horizontally, the highest position drain port should be used. If the shaft of a standard pump is installed vertically, an additional exhaust pipe should be connected to the top of the pump. When the drive side of the pump is located at the top, the flushing port "E" (1/4 ") located on the bearing boss should be used. If possible, this installation method should be avoided as much as possible!

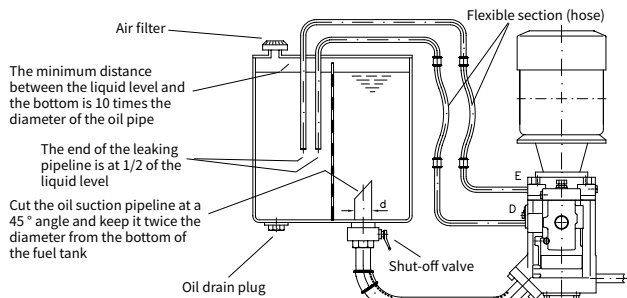

© by InLine Hydraulik GmbH.

The forwarding and reproduction of this document, as well as the use and communication of its contents, are forbidden unless expressly permitted.

Any breach or infringement will result in liability for damages.

All rights reserved concerning patent or utility model registrations.