

1.1



HRP03 series

Radial piston hydraulic motor

The HRP03 series radial piston hydraulic motor, is a kind of low speed high torque hydraulic motor, disc valve structure, with high pressure, good stability at low speed, high volumetric efficiency and mechanical efficiency.

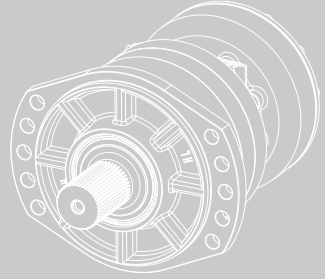

Contents

Overview	02
Advantages	02
Standard structure	02
Specification	03
Ordering information	04-07
Installation size	08-13
Speed sensor	14-15
Shaft end dimensions	16-17
Hydraulic diagram	18
Allowable shaft load/bearing curve	19-21
Rotation direction	22



Overview

The HRP03 series radial piston hydraulic motor, is a kind of low speed high torque hydraulic motor, disc valve structure, with high pressure, good stability at low speed, high volumetric efficiency and mechanical efficiency, and the motor can be equipped with various optional function modules.

Advantages

- Using tapered roller bearing structure, can support larger axial and radial load.
- Advanced disc valve structure, radial piston, high volumetric efficiency, high torque and high reliability.
- More options including brake, variable speed valve, speed sensor, etc.
- Can withstand high speed and high pressure working environment.

Standard structure

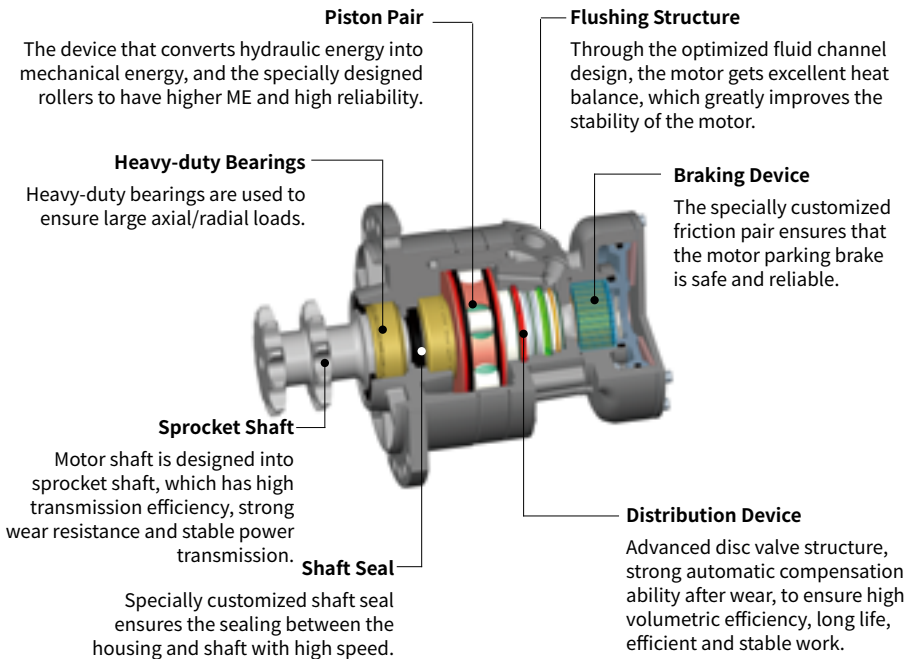

P - 0099

Specification

Series		HRP03						
Motor performance								
Displacement		cm ³ /rev.	160	225	255	325	365	400
Max.torque		N·m	1145	1611	1826	2069	2323	2546
Min.stable speed		rpm	5					
Max.speed	Displacement	rpm	670	475	420	330	295	270
	Variable displacement	rpm	875	620	550	430	385	350
Pressure	Max.differential pressure	bar	450			400		
Max.power		kW	18			22		
Weight	Single-speed	With brake	kg	35.202				
		Without brake	kg	25.6				
	Two-speed	With brake	kg	39.9				
		Without brake	kg	30.281				
Brake								
Static braking torque		N·m	2200					
Release pressure		bar	15 ~ 30					
Maximum pressure at brake port Z		bar	30					
Oil volume to operate brake		cm ³	23					

T - 0092

- Make sure the motor is full of oil before use.
- During motor running-in(at least 20 hours), it should not be operated without load at greater than 100rpm.
- The filtration standard of ISO 4406 cleaning standard 20/18/15 is recommended.
- High quality anti-wear hydraulic fluids are recommended.
- When the temperature is 50° , the minimum viscosity of the oil is recommended to be 20mm²/s.
- The recommended maximum operating temperature is 85° C.

Ordering information

HRP03	1	02	M2	S2	N	AA	B	AA
①	②	③	④	⑤	⑥	⑦	⑧	⑨

Radial Piston Series

①	Incurve multiple-action radial piston motor	HRP03
---	---	-------

Single and Two Speed

②	Single speed	1
	Two speed, gear ratio 2:1	2

Displacement cm³/rev.

③	160, Standard piston	01
	225, Standard piston	02
	255, Standard piston	03
	325, Step piston	05
	365, Step piston	06
	400, Step piston	07

Port Connection

	Single Speed:1	Two Speed:2	Code
7/8-14UNF(A, B), 9/16-18UNF(L), 3/4-16UNF(F)	●		M2/MB/MK/N8
G1/2(A, B), G3/8(L), G1/2(F)	●		M8/MV/MN/N9/NA
7/8-14UNF(A, B), 3/4-16UNF(L), 3/4-16UNF(F)	●		N2/M5/M9
G1/2(A, B), G3/8(L), G3/8(F)	●		M3/MA/MF/MH/ML/M6/N3
④ 1-1/16-12UN(A, B), 9/16-18UNF(L), 3/4-16UNF(F)	●		M7
7/8-14UNF(A, B), 9/16-18UNF(L), 3/4-16UNF(F), 9/16-18UNF(X)		●	M1/N5
G1/2(A, B), G1/4(L), G1/4(F), G1/4(X)		●	M4/ME/ND
7/8-14UNF(A, B), 3/4-16UNF(L), 3/4-16UNF(F), 9/16-18UNF(X)		●	MP
G1/2(A, B), G3/8(L), G3/8(F), G1/4(X)		●	NE

Ordering information

Output Shaft

	M2/MB/ M5/M9/ M3/MA/ MF/M7/ NA	N8/N9/ N2/N3/ MH/ ML/M6	MV/MK/ MN	M8	M1/MP/ NE	M4/ND/ ME/N5	Code
42 teeth splined shaft ANSIB92.1					●		S1
42 teeth splined shaft ANSIB92.1	●						S2
Double-sprocket 10 teeth, Chain No. 80(B29.1)	●						S3
Double-sprocket 9 teeth, Chain No. 100(ISO 606)	●						S5
Ø40 straight shaft, parallel key 12×8×70, center hole M12	●						SA
Wheel pilot Ø92.7×7, hub bolt Ø140 distribution circle 5×M14×1.5		●				●	W1
Ø40 short shaft, parallel key 12×8×65, center hole M12				●			S6
Double-sprocket 11 teeth, (GB/T 1243)	●						SB
Double-sprocket 9 teeth, Chain No. 100(GB/T 1243)	●						SH
⑤ Double-sprocket 9 teeth, Chain No. 100(ISO 606)	●						S4
17 teeth splined shaft SAE			●				SC
42 teeth splined shaft ANSIB92.1	●		●				S7
Ø40 shaft, parallel key 12×8×70, center hole M12, double bond slot			●				SD
Bolt hole 10×M12×1.75, distribution Ø110 round; wheel disc Ø140, pilot Ø62.8		●					W4
Wheel pilot Ø92.7×7, wheel bolts Ø140 distribution 5×M14×1.5, wheel disc thickness 12		●					W5
Pilot Ø77.6×6.5, wheel bolts Ø130 distribution 5×M14×1.5; wheel disc Ø170		●					W6
Pilot Ø77.6×6.5, wheel bolts Ø130 distribution 5×M14×1.5; wheel disc Ø170, 141.5 away from the flange surface		●					WF
Wheel pilot Ø92.7×7, wheel bolts Ø140 distribution 10×M14×1.5		●					W8
Double-sprocket 10T, Chain No. 80(B29.1)					●		SF
Pilot Ø92.7×7, wheel bolts Ø140 distribution 5×M16×1.5						●	W7

Ordering information

Paint Option

⑥	No Paint	N
	Black	B
	Hengli blue	C
	Yellow	Y

Brake

	M3/N2/N3/ M5/M7/M8/ M9/MA/MB/ MF/ML/N8/ N9	M2/M6	MV/ MN/ MH/ MK/NA	M1/M4/ MP/NE	N5/ME/ ND	代号
No brakes		●	●		●	AA
Static braking torque 2200N·m, port Z 9/16-18UNF	●	●				A1/A2
Static braking torque 2200N·m, port Z G1/4	●	●				A4
⑦ Static braking torque 2200N·m, port Z G1/4	●	●				A5
Static braking torque 2200N·m, port Z G3/8	●	●				A6
Static braking torque 2200N·m, port Z G1/4, M6 exhaust port	●	●				AD
Static braking torque 2200N·m, port Z G1/4	●	●		●	●	A3
Static braking torque 2200N·m, port Z G1/4	●	●				A7
Static braking torque 2200N·m, port Z 9/16-18UNF				●	●	A5/A8

Flushing Valve

	M1/N5/N2/M2/M3/ME/M4/N3/M5/M6/M7/ M8/MV/MN/M9/MA/MB/MF/MK/MP/N8/N9/ NA/ND/NE	MH/ML	代号
No flushing valve	○	●	A
There is a flushing valve with a flow rate of 5L/min	●		B
⑧ There is a flushing valve with a flow rate of 7L/min	●		C
There is a flushing valve with a flow rate of 10L/min	●		D
There is a flushing valve with a flow rate of 12.5L/min	●		E
There is a flushing valve with a flow rate of 13.5L/min	●		F

Ordering information

Special Features

	N5/N2/M2/M3/ME/N3/M5/M6/M7/ M8/MV/MN/M9/MA/MB/MF/MK/ MP/N8/NA/NE/MH/ML	M1/M4/N9/ND	代号
	●	●	AA
⑨ High temperature, FKM	●	●	V1
Low temperature	●	●	V2
Speed sensor cavity		●	S1
Speed sensor (with direction judgement)		●	S2

T - 0091

Note: ● =Available; ○ =Available on request; For the other types of port forms, output forms and brake port orientations, please contact Hengli's application engineer for consultation.

Installation size

· Single speed shaft output: Take HRP03107M2S2BA1BAA for example

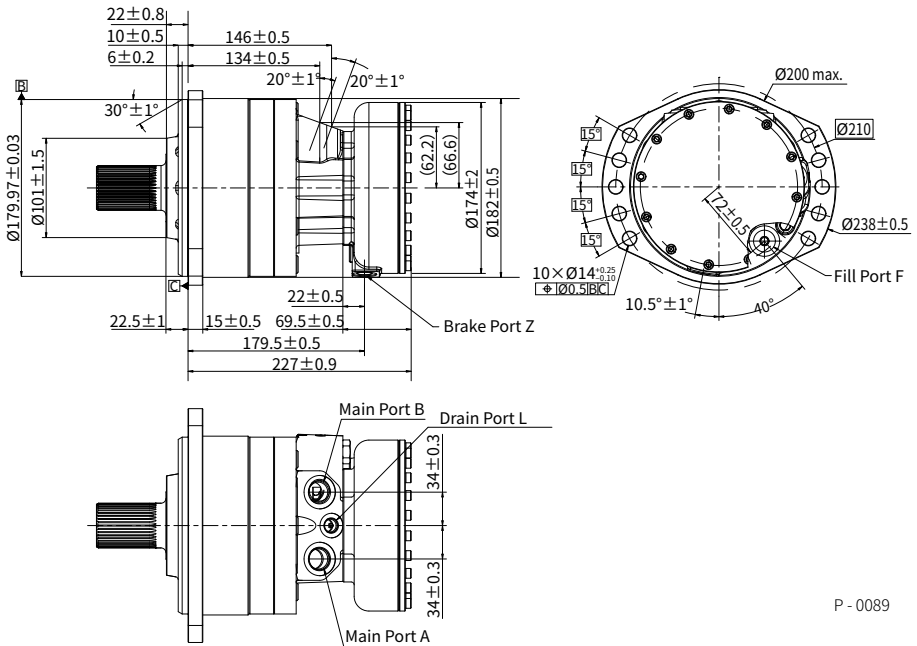

P - 0089

Note: The weight of the connection shown in the figure is 35kg.

Name	Port Function	M2/MB	M5/M9	M3/MA/MF	M7	NA
A, B	Main Port	7/8-14UNF	7/8-14UNF	G1/2	1-1/16-12UN	G1/2
L	Drain Port	9/16-18UNF	3/4-16UNF	G3/8	9/16-18UNF	G3/8
F	Fill Port	3/4-16UNF	3/4-16UNF	G3/8	3/4-16UNF	G1/2

T - 0093

Installation size

· Single speed wheel output: Take HRP03102M6W1BA3AAA for example

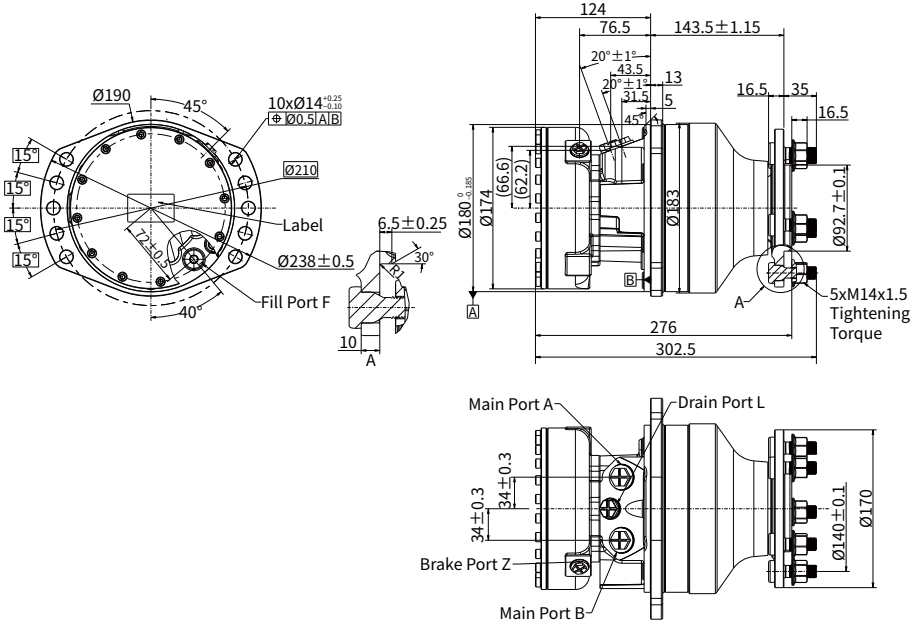

P - 0285

Note: The weight of the connection shown in the figure is 33kg.

Name	Port Function	N8	N9	N2	MH/ML/M6/N3
A, B	Main Port	7/8-14UNF	G1/2	7/8-14UNF	G1/2
L	Drain Port	9/16-18UNF	G3/8	3/4-16UNF	G3/8
F	Fill Port	3/4-16UNF	G1/2	3/4-16UNF	G3/8

T - 0213

Installation size

· Two speed shaft output: Take HRP03207M1S1BA5BAA for example

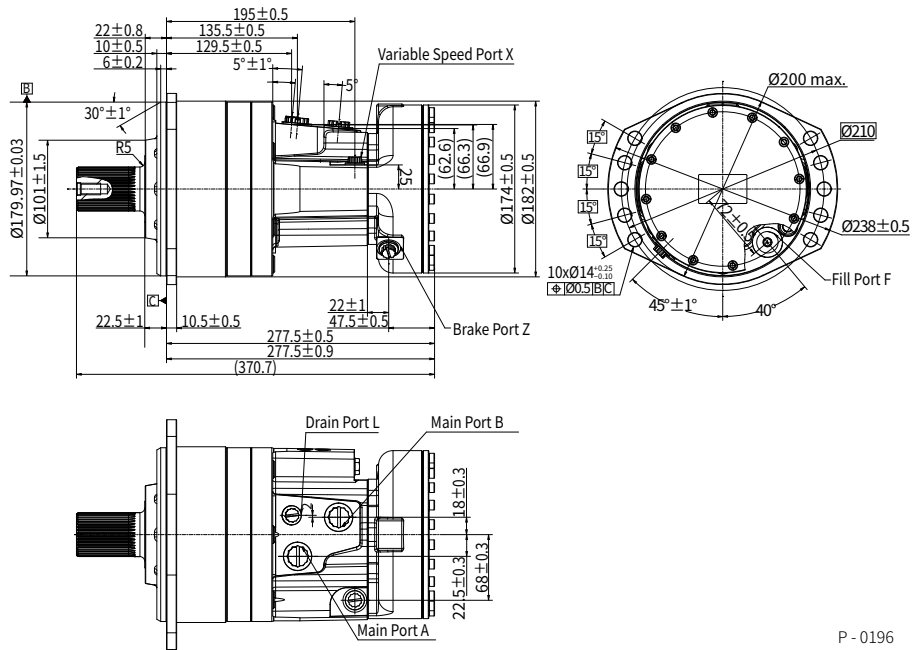

P - 0196

Note: The weight of the connection shown in the figure is 37.5kg.

Name	Port Function	M1	MP	NE
A, B	Main Port	7/8-14UNF	7/8-14UNF	G1/2
L	Drain Port	9/16-18UNF	3/4-16UNF	G3/8
F	Fill Port	3/4-16UNF	3/4-16UNF	G3/8
X	Variable Speed Port	9/16-18UNF	9/16-18UNF	G3/4

T - 0168

Installation size

• Two speed wheel output: Take HRP03207M4W1BA3BAA for example

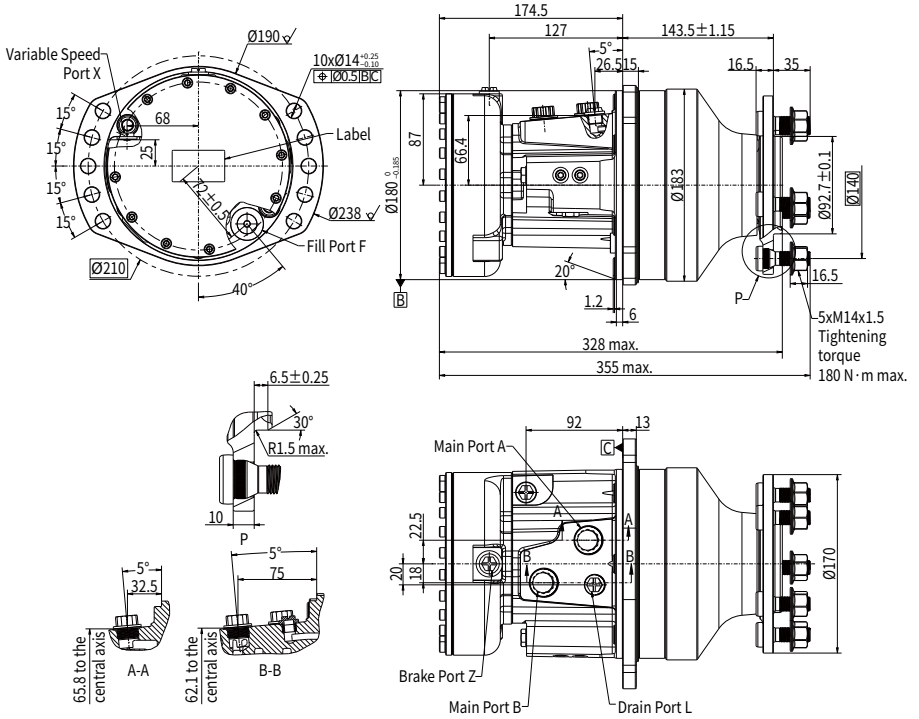

P - 0259

Note: The weight of the connection shown in the figure is 35.24kg.

Name	Port Function	M4/ME/ND	N5
A, B	Main Port	G1/2	7/8-14UNF
L	Drain Port	G1/4	9/16-18UNF
F	Fill Port	G1/4	3/4-16UNF
X	Variable Speed Port	G1/4	9/16-18UNF

T - 0199

Installation size

· 4-hole SAE flange: Take HRP03107MVSCBAAAA for example

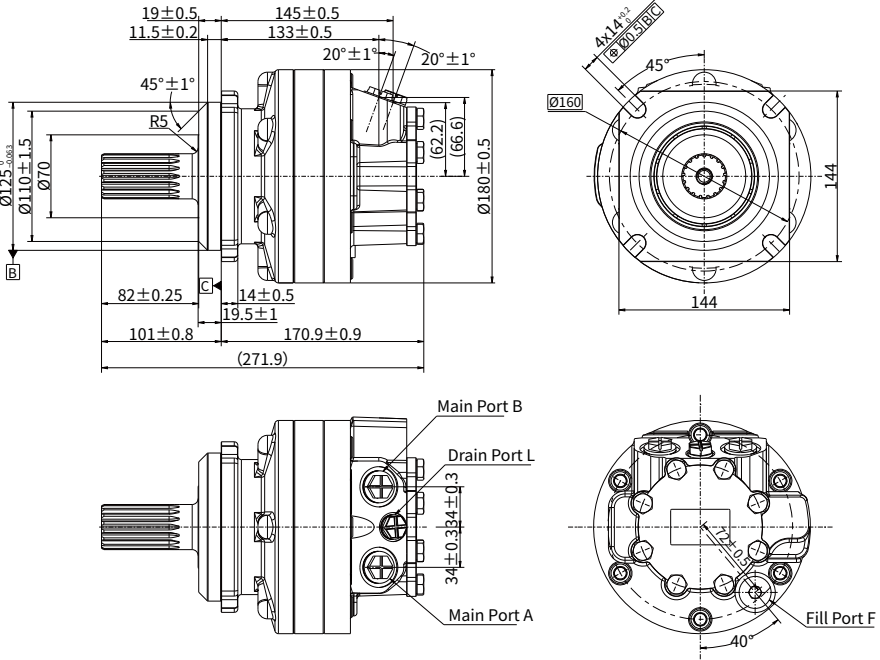

P - 0286

Note: The weight of the connection shown in the figure is 21.58kg.

Name	Port Function	MV/MN	MK
A, B	Main Port	G1/2	7/8-14UNF
L	Drain Port	G3/8	9/16-18UNF
F	Fill Port	G1/2	3/4-16UNF

T - 0214

Speed sensor

· Speed sensor: S2

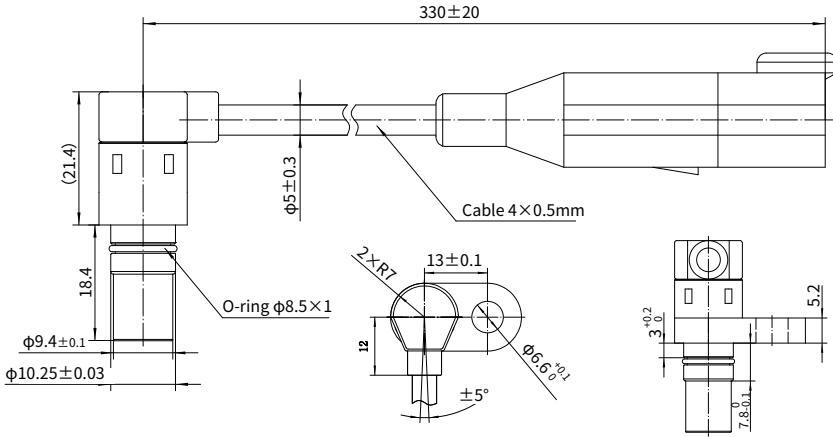

P - 0272

Dimensions	Ø10.25 /L=18.4mm
Voltage	8-32VDC
Input Current	<15mA
Sensing distance	0.2~2mm
Power reverse protection (Y/N)	Yes
Power input overcurrent and overvoltage protection (Y/N)	Yes
Maximum output current	50mA
Voltage drop	≤ 3VDC
Working frequency	0-20KHz
Output signal	A, B
Operating temperature	-40°C ~+125°C
Protection	IP67/IP69K
Shell material	Copper/plastic
Pressure resistance of measuring surface	10bar
Connector	Cable 0.33m, Injection 4-core DEUTSCH DT04-4P-EP04 plug

T - 0208

Speed sensor

· Speed sensor: S2

■ OUTPUT SIGNAL

⌚ The measured gear rotates clockwise

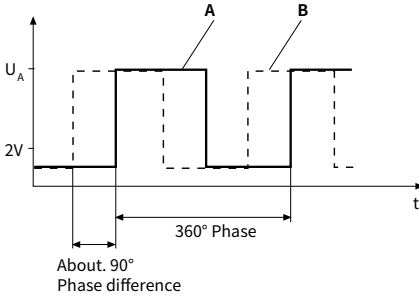

⌚ The measured gear rotates counterclockwise

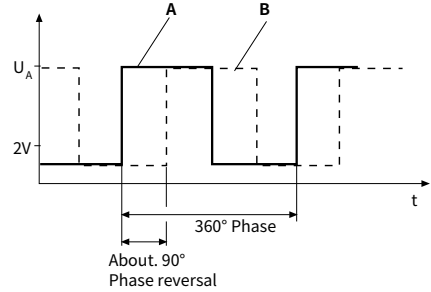

P - 0273

■ TERMINAL ASSIGNMENT

Signal		+Ub	0V	A	B
Color		BN	BU	BK	WH
4 core plug DT04		1	2	3	4

P - 0274

■ WIRING DIAGRAM

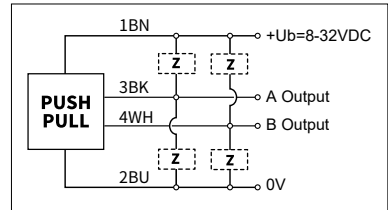

P - 0275

Shaft end dimensions

· Splined Shaft

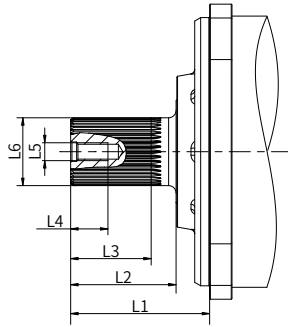

P - 0090

Code	L1		L2	L3	L4	L5	L6
S1/S2	93.2±0.8		70.7±0.3	54min.	25min.	M12	Ø45.52 ^{+0.25} ₀
SC	101±0.8		82±0.25	57min.			Ø38.1
S7	93.2±0.8 (*Suitable for common housings)	90.2±0.8 (*Suitable for 4-hole SAE flange housings)	71.2±0.25	54min.			Ø45.52 ^{+0.25} ₀

T - 0216

· Double-sprocket Shaft

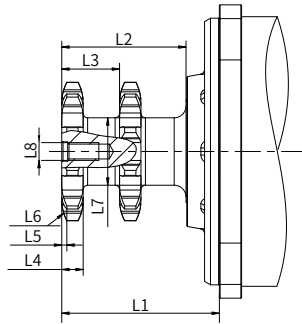

P - 0091

Code	L1	L2	L3	L4	L5	L6	L7	L8
S3	106.35±0.8	83.85±0.2	39±0.2	2x14.45 ⁰ _{-0.3}	4x3.43	4xR29.2	2xØ45.52 ^{+0.25} ₀	M12 _↓ 25 min.
S5	122.65±0.8	97.65±0.2	47±0.2	2x17.58 ⁰ _{-0.3}	4x4.128	4xR31.75	2xØ58 ^{+0.25} ₀	
SB	109±0.8	86.5±0.2	40±0.2	2x15 ⁰ _{-0.3}	4x3.3	4xR25.4	2xØ60 ^{+0.25} ₀	
SH	103.8±0.3	81.3±0.2	47±0.2	2x17.95 ⁰ _{-0.43}	4x4.1	4xR31.75	2xØ59±0.1	
S4	126.5±0.5	101.5±0.2	54±0.2	2x17.58 ⁰ _{-0.43}	4x4.128	4xR31.75	2xØ58 ^{+0.25} ₀	
SF	106.35±0.3	83.85±0.2	39±0.2	2x14.45 ⁰ _{-0.3}	4x3.43	4xR29.2	2xØ45.52 ^{+0.25} ₀	

T - 0217

Shaft end dimensions

·Straight Shaft

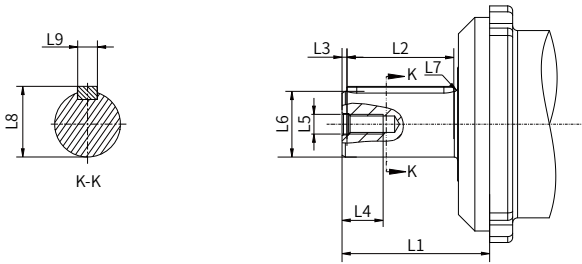

P - 0246

Code	L1	L2	L3	L4	L5	L6	L7	L8	L9
SA	114.6±0.8	70 ⁰ _{-0.74}	5±0.25	25 min.	M12	Ø40 ^{+0.018} _{+0.002}	R3.5	43 ⁰ _{-0.3}	12 ⁰ _{-0.043}
S6	89.8±0.8	65 ⁰ _{-0.74}	3±0.25			Ø40 ⁰ _{-0.016}	R2		
SD	111.6±0.8	2x70 ⁰ _{-0.74}	2x5±0.25			Ø40 ⁰ _{-0.016}	R3.5		

T - 0218

·Wheel Bolts

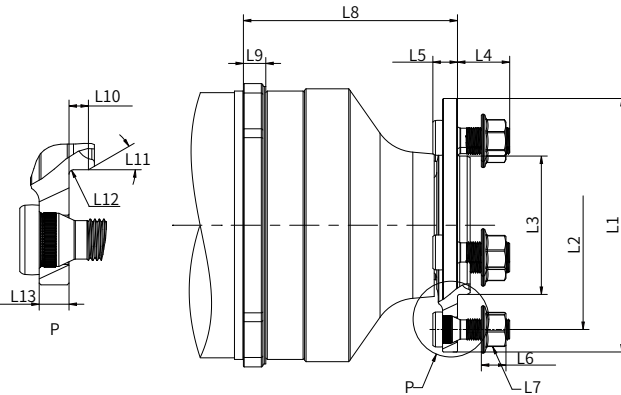

P - 0245

Code	L1	L2	L3	L4	L5	L6	L7	L8	L9	L10	L11	L12	L13
W1	Ø170	Ø140	Ø92.7±0.1	35	16.5	16.5	5xM14x1.5	143.5±1.15	15	6.5±0.25	30°	R1.5 max.	10
W4	Ø140	Ø110±0.1	Ø62.8±0.1	-	-	-	10xM12x1.75	151.2	13	-	-	-	-
W5	Ø170	Ø140±0.1	Ø92.7±0.1	33	18.5	16.5	5xM14x1.5	143.5±1.15	13	6.5±0.25	30°	R1	12
W6	Ø170	Ø130±0.1	Ø77.6±0.1	35	16.5	16.6	5xM14x1.5	145.5±1.15	13	6.5±0.25	30°	R1	10
W7	Ø170	Ø140	Ø92.7±0.1	40	15	21	5xM16x1.5	145.5±1.15	15	6.5±0.25	30°	R1 max.	10
W8	Ø170	Ø140±0.1	Ø92.7±0.1	35	16.5	16.6	10xM14x1.5	143.5±1.15	13	6.5±0.25	30°	R1	10
WF	Ø170	Ø140±0.1	Ø77.6 ⁰ _{-0.05}	35	16.5	16.5	5xM14x1.5	141±0.5	13	6.5	30°	R1	10

T - 0219

Hydraulic diagram

· Motor without brakes

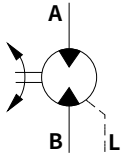

P - 0085

· Motor with parking brake

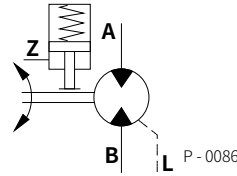

P - 0086

· Schematic diagram of a two-speed motor

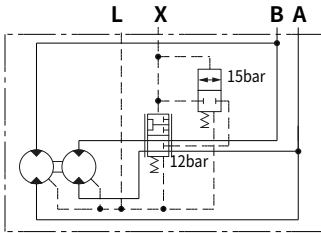

P - 0087

· Flushing valve schematic

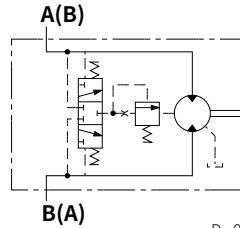

P - 0088

Allowable shaft load/bearing curve

As shown in the figure, when the axial load is 0, the radial allowable load of the output shaft is related to the distance from the flange mounting surface to the load action point.

The solid line shows the allowable radial load of the bearing based on life with 2000hrs. Denote use hydraulic fluids containing anti-wear additives, and rated output torque and motor speed of 50rpm, the differential pressure is 250 bar, the operating oil temperature is 50°C .

· Shaft Output Bearing Curve

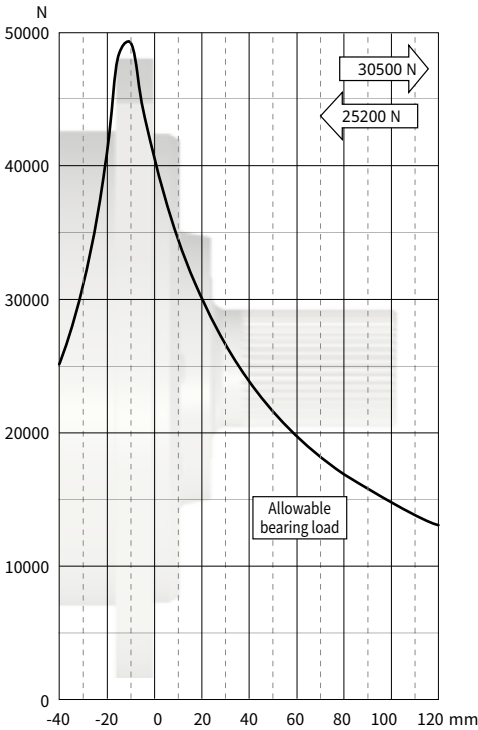

P - 0093

01

Allowable shaft load/bearing curve

· Wheel Output Bearing Curve

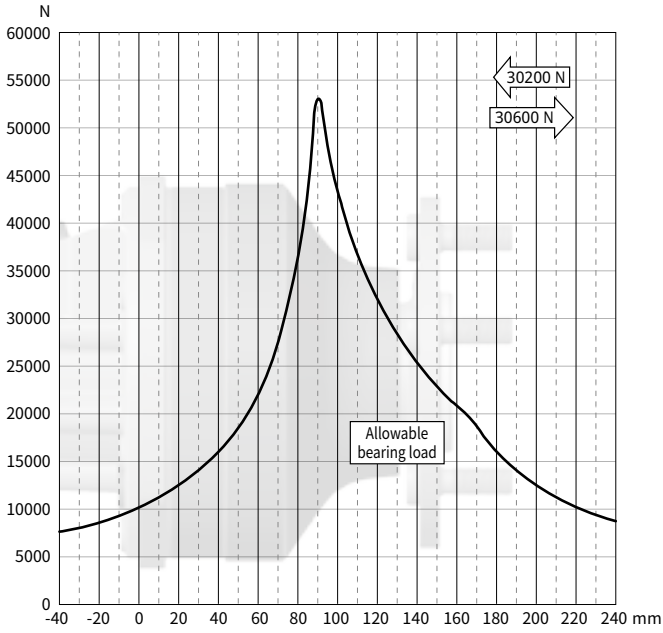

P - 0232

Allowable shaft load/bearing curve

· SAE Flange Output Bearing Curve

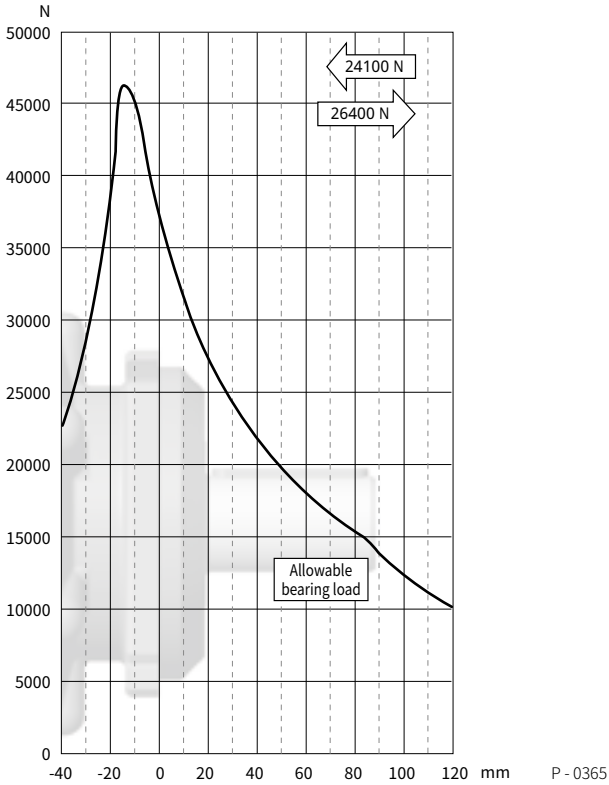

01

Rotation direction: CW

When facing the motor shaft extension direction, port A is high pressure oil, the output shaft rotates CW; Otherwise, it rotates CCW.

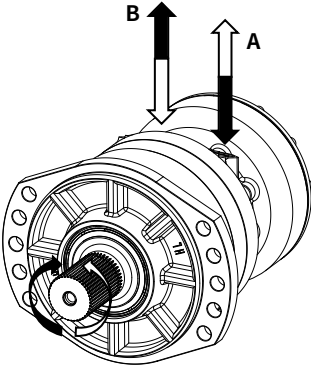

P - 0097